

MA 356-001 power unit

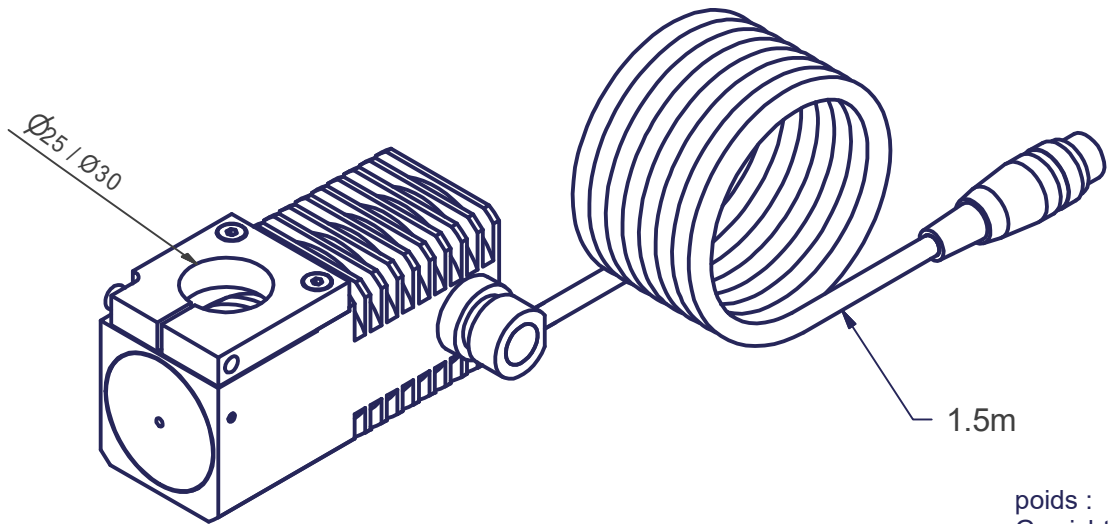
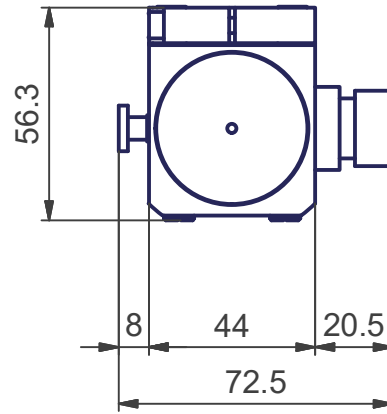
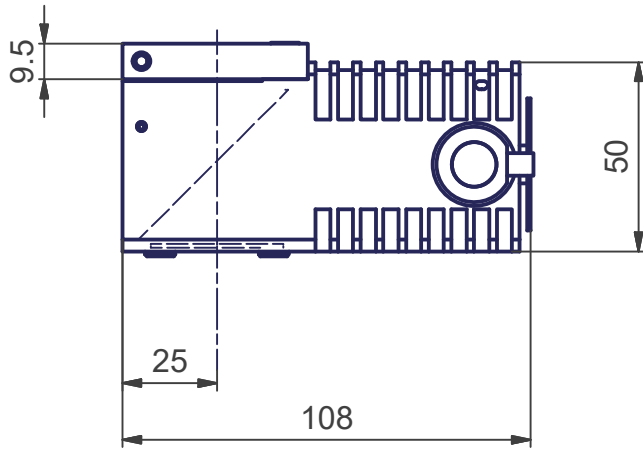
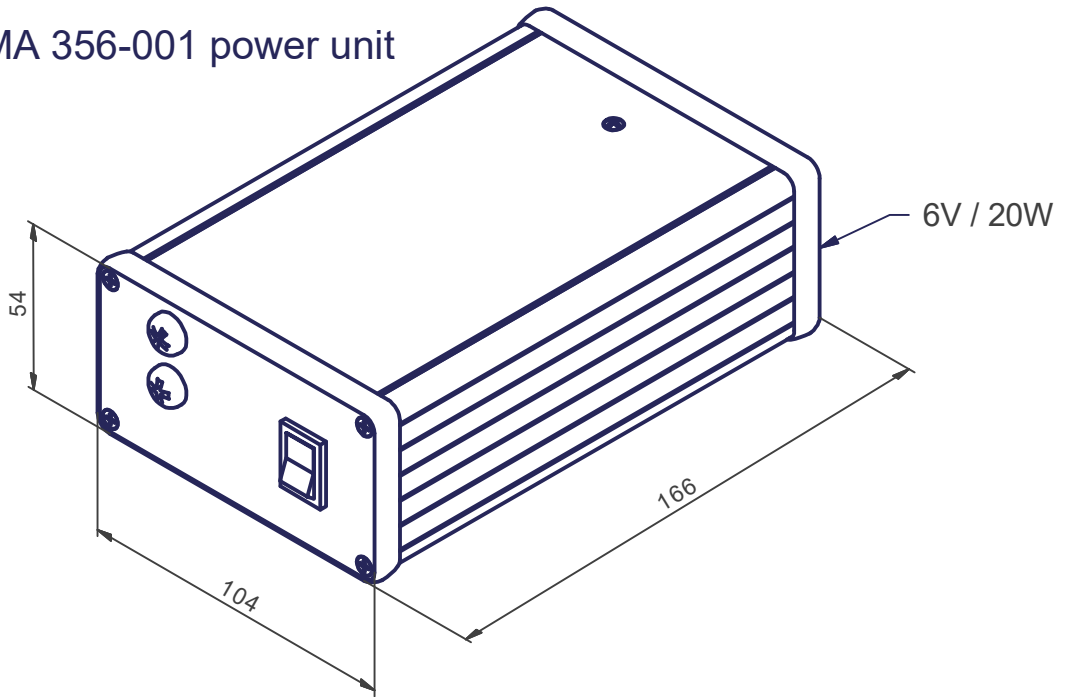

pois :  
Gewicht : ~400g  
weight :

Mod. 1	0739/06.08.2001	Mod. 3		Origine		Echelle	Nom	M.Saam
Mod. 2		Mod. 4		Rempl.		1 : 2	Date	13.04.2017
Libellé	Eclairage épiscopique Auflichtbeleuchtung Incident light illuminator			N° de plan	MA 213-4c		Catégorie	\$20-1
marcel - aubert - sa				Code article	ECL-...		N° de page	1 / 1